

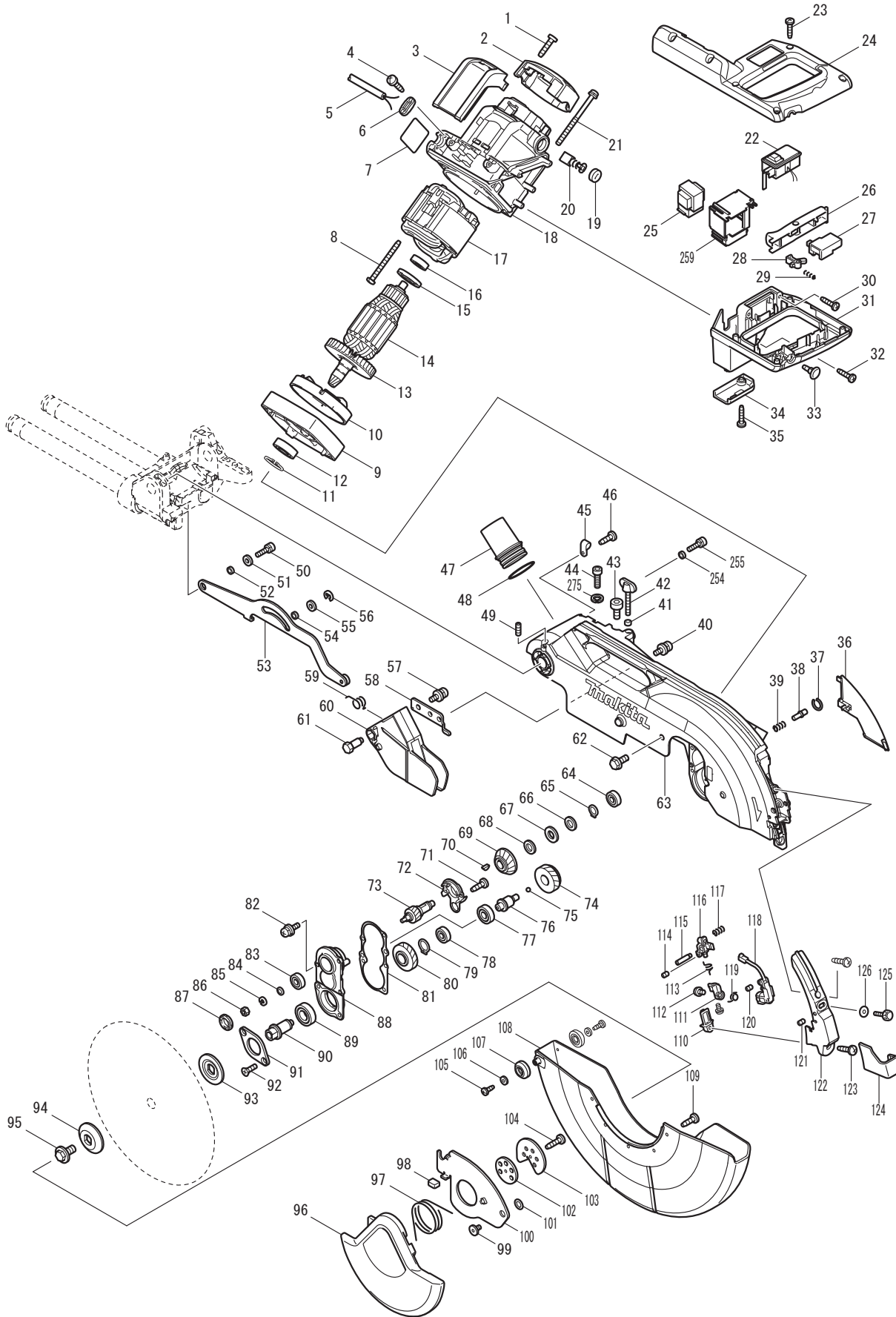

12 - 2010

LS1216L

12" SLIDE COMPOUND SAW W/LASER



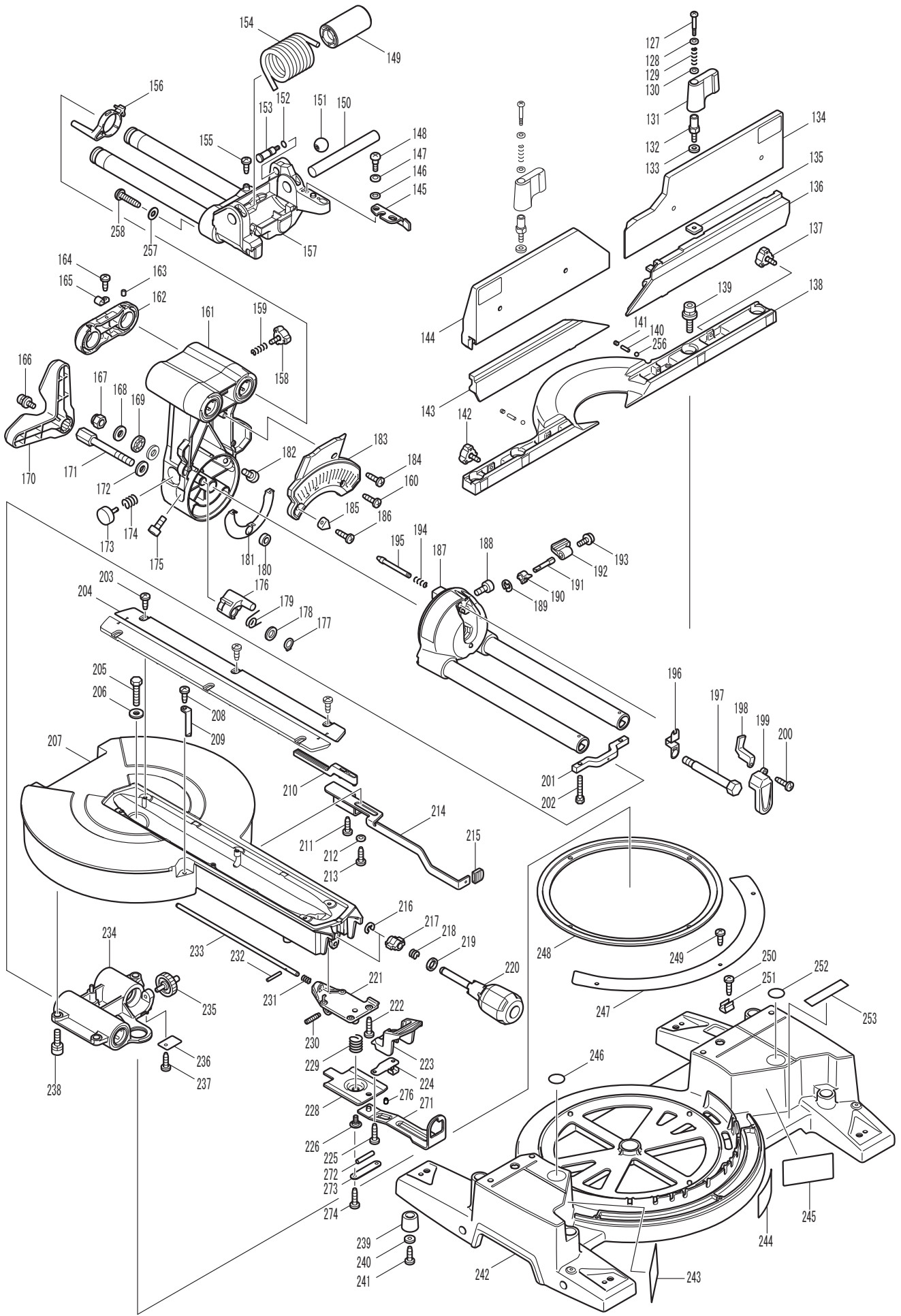

Item No	Type	Ref	Part No	Description	Qty	Unit
1			265995-6	TAPPING SCREW 4X18	2	PC.
2			450999-3	REAR COVER	1	PC.
3			631863-9	CONTROLLER	1	PC.
4			265995-6	TAPPING SCREW 4X18	2	PC.
5			664463-0	CORD W/PLUG 2P-14-2.5M, SJ	1	PC.
6			687052-4	STRAIN RELIEF	1	PC.
7			866948-4	LS1216L NAME PLATE	1	PC.
8			266329-6	TAPPING SCREW 5X60	2	PC.
9			318471-0	MOTOR BRACKET	1	PC.
10			451194-8	BAFFLE PLATE	1	PC.
11			961057-5	RETAINING RING S-17	1	PC.
12	1		211275-8	BALL BEARING 6003DDW	1	PC.
	2		210301-0	BALL BEARING 6003DDW	1	PC.
13			240001-8	FAN 80	1	PC.
14			517841-2	ARMATURE ASSEMBLY 115V	1	PC.
		INC.		Item No. 13,15,16	1	PC.
15			681642-5	INSULATION WASHER	1	PC.
16			211062-5	BALL BEARING 6000ZZ	1	PC.
17			596356-2	FIELD ASSEMBLY 115V	1	PC.
		INC.	654020-2	RING TERMINAL	2	PC.
		INC.	654553-7	CONNECTOR 34137	2	PC.
18			158958-8	MOTOR HOUSING COMPLETE	1	PC.
		INC.	643660-1	BRUSH HOLDER 6.5-13.5	2	PC.
19			643650-4	BRUSH HOLDER CAP 6.5-13.5	2	PC.
20			194986-9	CARBON BRUSH CB-154 2PC/SET (W/ ORIGIN)	1	SET
21			911948-0	PAN HEAD SCREW M6X80 WITH WR	4	PC.
22			638652-3	LASER SWITCH UNIT	1	PC.
23			265995-6	TAPPING SCREW 4X18	6	PC.
24			158981-3	HANDLE COVER COMPLETE	1	PC.
25			631907-5	POWER SUPPLY CIRCUIT	1	PC.
26			451003-1	SWITCH LEVER	1	PC.
27			650618-3	SWITCH TG72B-1	1	PC.
28			416356-5	LOCK-OFF LEVER	1	PC.
29			231026-3	COMPRESSION SPRING 4	1	PC.
30			265995-6	TAPPING SCREW 4X18	2	PC.
31			140047-3	HANDLE COMPLETE	1	PC.
		INC.	810484-2	CAUTION LABEL	1	PC.
32			265995-6	TAPPING SCREW 4X18	2	PC.
33			451037-4	SWITCH BUTTON	1	PC.
34			451000-7	LEAD COVER HOLDER	1	PC.
35			265995-6	TAPPING SCREW 4X18	1	PC.
36			451199-8	LEAD COVER	1	PC.
37			231928-3	RING SPRING 8	1	PC.
38			256633-1	PIN 6	1	PC.
39			231240-1	COMPRESSION SPRING 7	1	PC.
40			911113-1	PAN HEAD SCREW M4X10	2	PC.
41			262001-8	URETHANE RING 5	1	PC.
42			265717-4	SCREW M6X43	1	PC.
43			266488-6	HEX SOCKET HEAD BOLT M8X20	1	PC.
44			922332-4	HEX. SOCKET HEAD BOLT M6X20	1	PC.
45			687095-6	STRAIN RELIEF	1	PC.
46			266026-4	TAPPING SCREW BIND CT 4X12	1	PC.
47			419277-0	DUST NOZZLE	1	PC.
48			213460-9	O RING 35	1	PC.

Item No	Type	Ref	Part No	Description	Qty	Unit
49			266321-2	H.S.SET SCREW(FLAT POINT)M6X16	1	PC.
50			922331-6	HEX. SOCKET HEAD BOLT M6X20	1	PC.
51			253804-1	FLAT WASHER 6	1	PC.
52			257163-5	RING 6	1	PC.
53			140164-9	LINK PLATE COMPLETE	1	PC.
54			257163-5	RING 6	1	PC.
55			253804-1	FLAT WASHER 6	1	PC.
56			961018-5	STOP RING E-5	1	PC.
57			911113-1	PAN HEAD SCREW M4X10	1	PC.
58			346050-4	GUARD HOLDER	1	PC.
59			231675-6	TORSION SPRING 11	1	PC.
60	1		451198-0	GUARD - N/L/A	1	PC.
	2		453635-0	GUARD	1	PC.
61			325645-6	GUARD SHAFT	1	PC.
62			265324-3	HEX. FLANGE HEAD BOLT M8X12	1	PC.
63			140151-8	BLADE CASE COMPLETE	1	PC.
		INC.	263005-3	RUBBER PIN 6	3	PC.
		INC.	810106-4	LASER BEAM CAUTION LABEL	1	PC.
		INC.	810124-2	LASER BEAM CAUTION LABEL	1	PC.
64			210005-4	BALL BEARING 608DDW	1	PC.
65			961052-5	RETAINING RING S-12	1	PC.
66			253744-3	FLAT WASHER 12	1	PC.
67			261104-5	RUBBER WASHER 12	1	PC.
68			253744-3	FLAT WASHER 12	1	PC.
69			227550-2	SPIRAL BEVEL GEAR 32	1	PC.
70			254001-2	WOODRUFF KEY 4	1	PC.
71			266026-4	TAPPING SCREW BIND CT 4X12	2	PC.
72			451002-3	GREASE HOLDER	1	PC.
73			227701-7	HELICAL GEAR 14	1	PC.
74			227702-5	HELICAL GEAR 27	1	PC.
75			216024-8	STEEL BALL 4	1	PC.
76			325643-0	GEAR SHAFT	1	PC.
77			211062-5	BALL BEARING 6000ZZ	1	PC.
78			210005-4	BALL BEARING 608DDW	1	PC.
79			961055-9	RETAINING RING S-15	1	PC.
80			227703-3	HELICAL GEAR 28	1	PC.
81			442147-8	GASKET	1	PC.
82			911223-4	PAN HEAD SCREW M5X16	3	PC.
83			210005-4	BALL BEARING 608DDW	1	PC.
84			267010-2	FLAT WASHER 5	1	PC.
85			942101-7	SPRING WASHER 5	1	PC.
86			931202-6	HEX. NUT M5	1	PC.
87			285847-5	BEARING RETAINER 14-23	1	PC.
88			158957-0	BEARING BOX COMPLETE	1	PC.
		INC.	263002-9	RUBBER PIN 4	1	PC.
89			211236-8	BALL BEARING 6002DDW	1	PC.
90			325644-8	SPINDLE	1	PC.
91			285732-2	BEARING RETAINER 51	1	PC.
92			265034-2	+ COUNTERSUNK HEAD SCREW M5X16	2	PC.
93			224431-1	INNER FLANGE 53	1	PC.
94			224432-9	OUTER FLANGE 53	1	PC.
95			265405-3	HEX. FRANGE HEAD BOLT M10X20	1	PC.
96			158959-6	* SAFETY COVER A COMPLETE	1	PC.
97			233554-4	TORSION SPRING 45	1	PC.

Item No	Type	Ref	Part No	Description	Qty	Unit
98			424190-9	CUSHION	1	PC.
99			265985-9	HEX.SOCKET HEAD BOLT M6	1	PC.
100			346048-1	CENTER COVER	1	PC.
101			253932-2	WAVE WASHER 10	1	PC.
102			344539-6	CENTER WASHER	1	PC.
103			346047-3	CENTER PLATE	1	PC.
104			266034-5	TAPPING SCREW CT 4X16	1	PC.
105			266020-6	TAPPING SCREW 4X12	2	PC.
106			941051-3	FLAT WASHER 4	2	PC.
107			424193-3	ROLLER	2	PC.
108			451197-2	SAFETY COVER B	1	PC.
109			266026-4	TAPPING SCREW BIND CT 4X12	3	PC.
110			418104-8	LENS	1	PC.
111			419378-4	BLOCK B	1	PC.
112			911003-8	PAN HEAD SCREW M3X6	2	PC.
113			231664-1	TORSION SPRING 9	1	PC.
114			266318-1	H.S.SET SCREW(FLAT POINT)M4X6	1	PC.
115			266306-8	SHOULDER SCREW M5	1	PC.
116			419379-2	BLOCK C	1	PC.
117			233471-8	COMPRESSION SPRING 6	1	PC.
118			638651-5	LASER CIRCUIT COMPLETE	1	PC.
119			231664-1	TORSION SPRING 9	1	PC.
120			266318-1	H.S.SET SCREW(FLAT POINT)M4X6	1	PC.
121			266229-0	H.S.SET SCREW(CUP POINT)M5X8	2	PC.
122			451195-6	LASER COVER	1	PC.
123			266034-5	TAPPING SCREW CT 4X16	2	PC.
124			451038-2	PROTECTOR	1	PC.
125			265753-0	THUMB SCREW M5X24	1	PC.
126			253807-5	FLAT WASHER 5	1	PC.
127			265026-1	+ PAN HEAD SCREW M4	2	PC.
128			941102-2	FLAT WASHER 5	2	PC.
129			233267-7	COMPRESSION SPRING 7	2	PC.
130			941102-2	FLAT WASHER 5	2	PC.
131			272261-4	LEVER 45	2	PC.
132			325651-1	JOINT	2	PC.
133			253804-1	FLAT WASHER 6	2	PC.
134			140162-3	UPPER FENCE R COMPLETE	1	PC.
		INC.	810482-6	CAUTION LABEL	1	PC.
135			346058-8	GUIDE PLATE	2	PC.
136			318476-0	LOWER FENCE R	1	PC.
137			265783-1	THUMB SCREW M6X18	1	PC.
138			318411-8	GUIDE FENCE	1	PC.
139			922443-5	H.S.H.BOLT M8X25 WITH WR	4	PC.
140			256226-4	PIN 4	2	PC.
141			266264-8	H.S.SET SCREW(FLAT POINT)M5X6	2	PC.
142			265783-1	THUMB SCREW M6X18	1	PC.
143	1		318475-2	LOWER FENCE L	1	PC.
	2		318863-3	LOWER FENCE L	1	PC.
144			140158-4	UPPER FENCE L COMPLETE	1	PC.
		INC.	810481-8	CAUTION LABEL	1	PC.
145			346049-9	STOPPER ARM	1	PC.
146			253948-7	WAVE WASHER 8	1	PC.
147			253835-0	FLAT WASHER 8	1	PC.
148			251267-5	+ PAN HEAD SCREW M6	1	PC.

Item No	Type	Ref	Part No	Description	Qty	Unit
149			451202-5	SLEEVE 17	1	PC.
150			323740-6	ROD 16	1	PC.
151			271601-3	KNOB 20	1	PC.
152			213011-8	O RING 7	1	PC.
153			322629-5	STOPPER PIN	1	PC.
154			233542-1	TORSION SPRING 40	1	PC.
155			266026-4	TAPPING SCREW BIND CT 4X12	1	PC.
156			158962-7	STOPPER LEVER COMPETE	1	PC.
		INC.	263002-9	RUBBER PIN 4	1	PC.
157	4		140976-0	* FRONT ARM COMPLETE (W/O Screw Hole)	1	PC
158			265783-1	THUMB SCREW M6X18	1	PC.
159			231240-1	COMPRESSION SPRING 7	1	PC.
160			266034-5	TAPPING SCREW CT 4X16	1	PC.
161			140155-0	ARM COMPLETE	1	PC.
		INC.	262077-5	FELT RING 25	4	PC.
		INC.	263005-3	RUBBER PIN 6	1	PC.
		INC.	344638-4	CAP 35	3	PC.
162			318403-7	HOLDER	1	PC.
163			266208-8	* H.S.SET SCREW(CUP POINT)M6X8	2	PC.
164			266026-4	TAPPING SCREW BIND CT 4X12	1	PC.
165			687095-6	STRAIN RELIEF	1	PC.
166			911113-1	PAN HEAD SCREW M4X10	1	PC.
167			252130-5	HEX. LOCK NUT M10-17	1	PC.
168			253024-7	FLAT WASHER 10	2	PC.
169			216413-7	THRUST NEEDLE CAGE 1024	1	PC.
170			451019-6	LEVER 105	1	PC.
171			265589-7	HEX BOLT M10	1	PC.
172			253024-7	FLAT WASHER 10	1	PC.
173			415208-7	RELEASE BUTTON	1	PC.
174			233031-6	COMPRESSION SPRING 12	1	PC.
175			266488-6	HEX SOCKET HEAD BOLT M8X20	1	PC.
176			318405-3	STOPPER	1	PC.
177			961052-5	RETAINING RING S-12	1	PC.
178			253744-3	FLAT WASHER 12	1	PC.
179			231646-3	TORSION SPRING 14	1	PC.
180			262158-5	RUBBER RING 9	1	PC.
181			346071-6	PLATE	1	PC.
182			266488-6	HEX SOCKET HEAD BOLT M8X20	1	PC.
183			451200-9	ARM COVER	1	PC.
184			266034-5	TAPPING SCREW CT 4X16	1	PC.
185			343678-9	POINTER	1	PC.
186			266034-5	TAPPING SCREW CT 4X16	1	PC.
187			158964-3	ARM HOLDER COMPLETE	1	PC.
		INC.	263005-3	RUBBER PIN 6	1	PC.
		INC.	816927-2	BEVEL SCALE LABEL	1	PC.
188			266488-6	HEX SOCKET HEAD BOLT M8X20	1	PC.
189			961011-9	STOP RING E-4	1	PC.
190			451044-7	CAM	1	PC.
191			325656-1	ROD 6	1	PC.
192			272262-2	LEVER 22	1	PC.
193			911113-1	PAN HEAD SCREW M4X10	1	PC.
194			234122-6	COMPRESSION SPRING 6	1	PC.
195			325865-2	LOCK PIN 8	1	PC.
196			232250-1	LEAF SPRING	1	PC.

Item No	Type	Ref	Part No	Description	Qty	Unit
197			325646-4	CENTER SHAFT	1	PC.
198			451039-0	POSITION PLATE	1	PC.
199			451070-6	ARM HOLDER COVER	1	PC.
200			266034-5	TAPPING SCREW CT 4X16	1	PC.
201			158967-7	SQUARE ROD COMPLETE	1	PC.
		INC.	263005-3	RUBBER PIN 6	1	PC.
202			925251-3	HEX.BOLT M5X30	2	PC.
203			266026-4	TAPPING SCREW BIND CT 4X12	6	PC.
204			451201-7	KERF BOARD	2	PC.
205			265585-5	HEX BOLT M8X45	1	PC.
206			253762-1	FLAT WASHER 8	1	PC.
207			140167-3	TURN BASE COMPLETE	1	PC.
		INC.	816930-3	INDICATION LABEL	1	PC.
		INC.	816787-2	INDICATION LABEL	1	PC.
208			266026-4	TAPPING SCREW BIND CT 4X12	1	PC.
209			451009-9	INDICATION PLATE	1	PC.
210			451011-2	RACK BLOCK	1	PC.
211			266385-6	TAPPING SCREW 4X14	1	PC.
212			941051-3	FLAT WASHER 4	1	PC.
213			266026-4	TAPPING SCREW BIND CT 4X12	1	PC.
214			346052-0	SLIDE LOCK PLATE	1	PC.
215			286275-7	CAP	1	PC.
216			961013-5	STOP RING E-7	1	PC.
217			313165-2	CAM	1	PC.
218			231131-6	COMPRESSION SPRING 11	1	PC.
219			267047-9	FLAT WASHER 10	1	PC.
220			273666-1	GRIP 50	1	PC.
221			318410-0	PIN HOLDER	1	PC.
222			266034-5	TAPPING SCREW CT 4X16	4	PC.
223			451010-4	LOCK LEVER	1	PC.
224			345272-3	LOCK LEVER PLATE	1	PC.
225			266034-5	TAPPING SCREW CT 4X16	2	PC.
226			266505-2	H.S. BINDING HEAD SCREW M6X14	1	PC.
228			346094-4	MITER LOCK PLATE A	1	PC.
229			234104-8	COMPRESSION SPRING 13	1	PC.
230			266306-8	SHOULDER SCREW M5	1	PC.
231			231325-3	COMPRESSION SPRING 6	1	PC.
232			256158-5	PIN 3	1	PC.
233			325695-1	LOCK PIN 6	1	PC.
234			158968-5	LINEAR BEARING BOX COMPLETE	1	PC.
235			451018-8	SPUR GEAR 43	1	PC.
236			232249-6	LEAF SPRING	1	PC.
237			266026-4	TAPPING SCREW BIND CT 4X12	1	PC.
238			922441-9	HEX. SOCKET HEAD BOLT M8X25	3	PC.
239			421845-7	FOOT	4	PC.
240			267195-4	FLAT WASHER 4	4	PC.
241			266026-4	TAPPING SCREW BIND CT 4X12	4	PC.
242			140052-0	* BASE COMPLETE	1	PC.
		INC.		Item No. 243, 246, 252, 253	1	PC.
243			810493-1	CAUTION LABEL	1	PC.
246			817283-3	CAUTION LABEL	1	PC.
247			816920-6	MITER SCALE PLATE	1	PC.
248			451012-0	SLIDE PLATE	1	PC.
249			266026-4	TAPPING SCREW BIND CT 4X12	3	PC.

Item No	Type	Ref	Part No	Description	Qty	Unit
250			266034-5	TAPPING SCREW CT 4X16	1	PC.
251			232075-3	LEAF SPRING	1	PC.
252			817283-3	CAUTION LABEL	1	PC.
253			810488-4	CAUTION LABEL	1	PC.
254			257785-1	SLEEVE 6	1	PC.
255			922226-3	HEX. SOCKET HEAD BOLT M5X18	1	PC.
256			216024-8	STEEL BALL 4	2	PC.
257			253874-0	FLAT WASHER 4	1	PC.
258			266042-6	TAPPING SCREW BIND CT 4X20	1	PC.
259			451412-4	CASE	1	PC.
271			140165-7	MITER LOCK PLATE B COMPLETE	1	PC.
272			256246-8	PIN 6	1	PC.
273			346096-0	PLATE	1	PC.
274			266034-5	TAPPING SCREW CT 4X16	2	PC.
275			942151-2	SPRING WASHER 6	1	PC.
276			266318-1	H.S.SET SCREW(FLAT POINT)M4X6	1	PC.
277			253313-0	* THIN WASHER 14 (Added)	1	PC.
280	3		346474-4	* PLATE (Old)	1	PC.
281			266026-4	* TAPPING SCREW CT4X12 (Old)	1	PC.
282			424438-9	* DUST FILTER (Added)	1	PC.
283			266318-1	* H.S.SET SCREW M4X6 (Added)	1	PC.
300			654558-7	INSULATED CONNECTOR	3	PC.
500			257060-5	ADAPTOR RING 15.8MM(1" TO 5/8")(4.0)	1	PC.
C10			870240-2	CARTON	1	PC.

ACCESSORIES

- See Catalogue or visit www.makita.ca for more accessories -

A01			122852-0	DUST BAG ASS'Y	1	PC.
	INC.		410602-8	FASTENER	1	PC.
A02			122854-6	VERTICAL VISE ASS'Y	1	PC.
	INC.		140037-6	VISE ARM A COMPLETE	1	PC.
	INC.		140038-4	VISE ARM B COMPLETE	1	PC.
	INC.		168522-7	SET PLATE	1	PC.
	INC.		251370-2	+ PAN HEAD SCREW M5	1	PC.
	INC.		251887-5	SCREW M6X10	1	PC.
	INC.		253744-3	FLAT WASHER 12	1	PC.
	INC.		253804-1	FLAT WASHER 6	1	PC.
	INC.		266026-4	TAPPING SCREW BIND CT 4X12	1	PC.
	INC.		271328-5	KNOB 40	1	PC.
	INC.		313163-6	RELEASE NUT R	1	PC.
	INC.		313164-4	RELEASE NUT L	1	PC.
	INC.		343651-9	VISE PLATE	1	PC.
	INC.		346053-8	NUT HOLDER	1	PC.
	INC.		346054-6	PROTECTOR	2	PC.
	INC.		961052-5	RETAINING RING S-12	1	PC.
A03			762001-3	TRIANGULAR RULE	1	PC.
A04			783208-8	HEX. WRENCH 2.5	1	PC.
A05			195240-4	HOLDER 200 SET	1	PC.
	INC.		265786-5	SCREW M5X16	2	PC.
	INC.		325673-1	HOLDER 200	2	PC.
A06			782232-8	BOX WRENCH 13	1	PC.
A07			A-93712	12" C.T. SAW BLADE, 60T	1	PC.
			721536-3	12" C.T.SAW BLADE 70T - BULK	1	PC.
A08			194943-7	SLIDE MITRE SAW STAND (See Partsbreakdown 194943-7)	1	PC.
A09			194061-1	BENCHTOP MITER SAW STAND (See Partsbreakdown 194061-1)	1	PC.

Item No	Type	Ref	Part No	Description	Qty	Unit
A10			195253-5	CROWN MOLDING STOPPER SET	1	PC.
A11			122930-6	HORIZONTAL VISE ASSY	1	PC.
A12			194175-6	DUST BOX (See Parts breakdown 194175-6)	1	PC.
A13			WST05	SLIDE MITRE SAW STAND (See Partsbreakdown WST05)	1	PC,

SERVICE CHANGES

1. Addition of Thin Washer 14 (T/l# 87277)

Item No	Description	Part No.
277	Thin Washer 14	253313-0

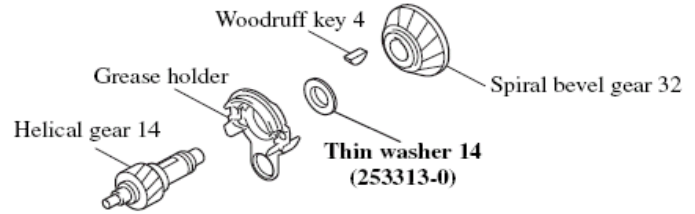

2. Changes on Front Arm Complete.

Item No	Description	(T/l# 88615)	(T/l# 90111)	(T/l# 91054)
157	Front Arm Complete	140154-2 (N/L/A)	140711-6 (N/L/A)	140976-0 (W/Screw Hole) / 140976-0 (W/O Screw Hole)
280	PLATE	---	---	346474-4 / -----
281	TAPPING SCREW	---	---	266026-4 / -----
282	DUST FILTER	---	---	424438-9

Item No.157, 278 - 279 are completely interchangeable as a set.

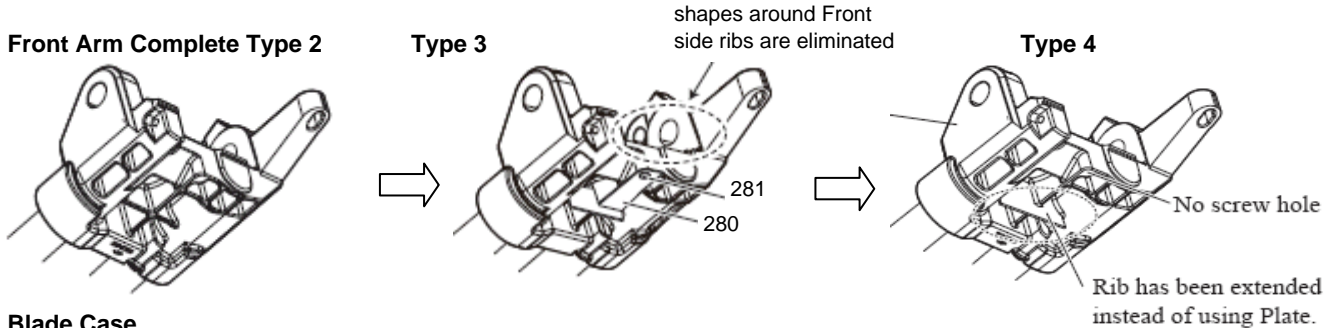

Blade Case

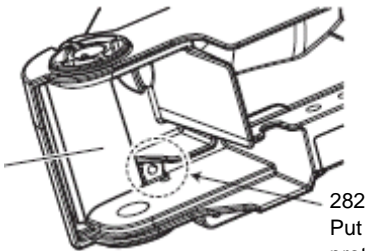

Put Dust filter along the inner wall of Blade case. Be sure to contact the end of Dust filter with the protrusion around female thread of Blade case as encircled by broken line.

3. Fastening torque for H.S.Set Screw Set M6X8

Item No.	Description	Part No.	Torque (Type1)	Torque (Type2)
163	H.S.SET SCREW	266208-8	3.1-6.3N.m (31-63kgf.cm)	4-6N.m (40-60kgf.cm)

When Slide pipe portions of the current Front arm complete are not slid smoothly due to their shifts by external impacts, loosen the two M6x8 H.S. set screws and remove Pipe holder, then assemble them again by tightening the screws to the fastening torque 4 up to 6 N.m.

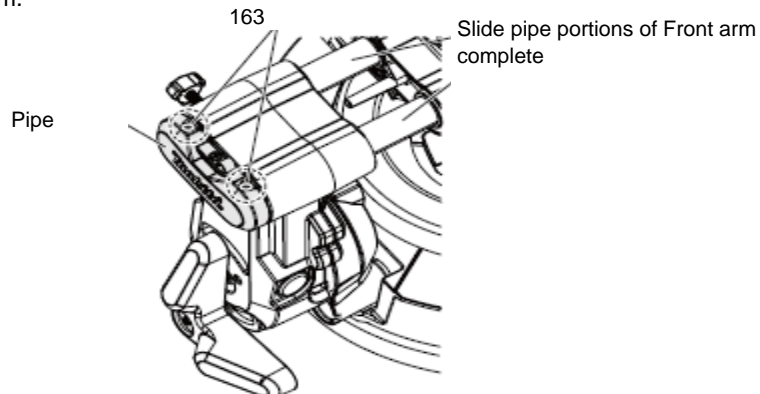

SERVICE CHANGES

4. Safety Cover A complete and addition of H.S.S. Screw (Flat point)

Item No.	Description	Type 1	Type 2
96	Safety Cover A Com.		158959-6
283	H.S.S Screw	-----	266318-1

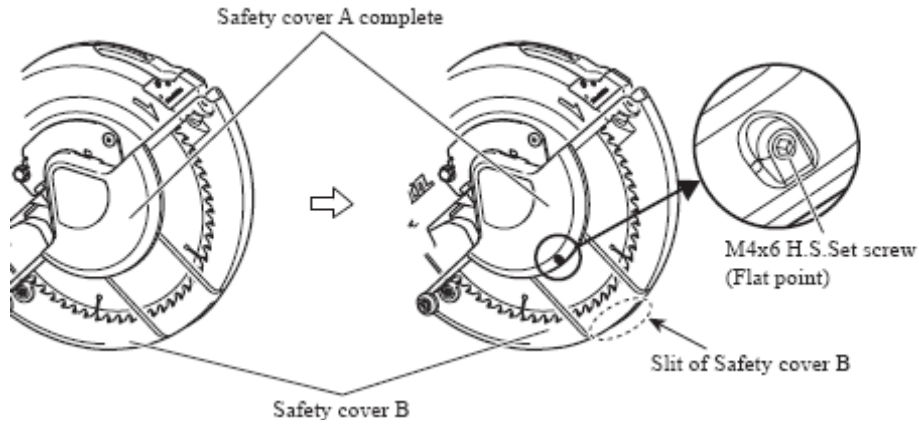

5. Makita grease SG No.0 has been added to the sliding surface as drawn below (T/I# 90978)

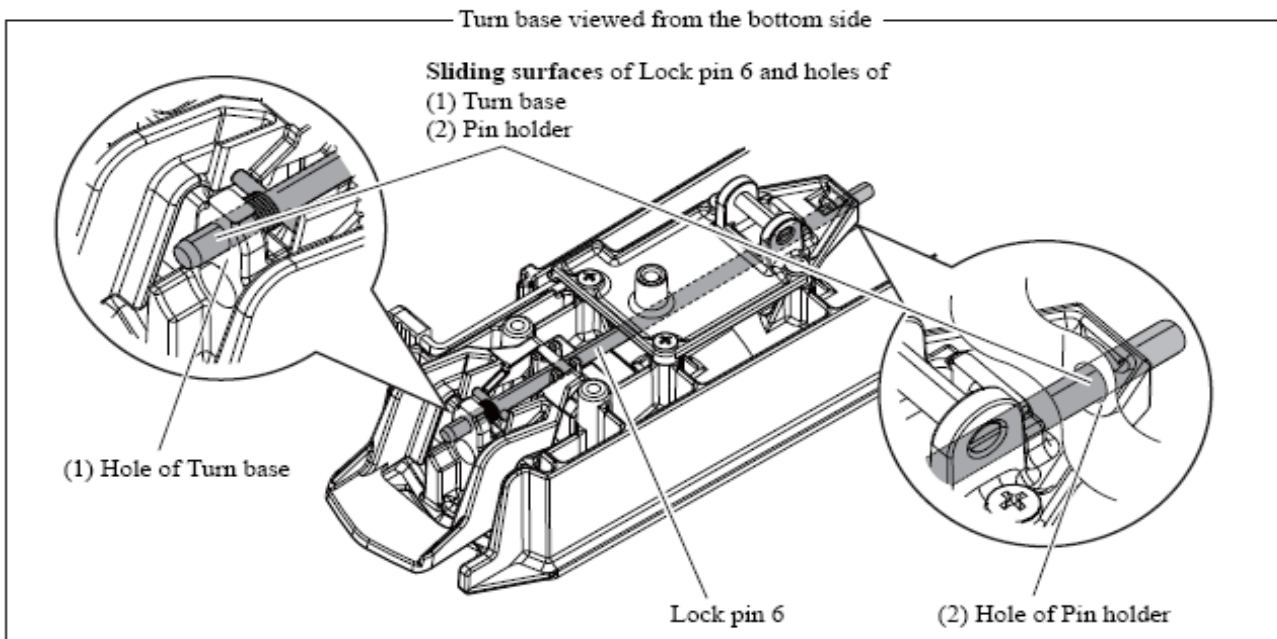

SERVICE CHANGES

5. Changes on Base Complete

(T/I# 96272)

Item No.	Description	Type 1	Type 2
242	Base Complete		140052-0

Type 2: Ribs have been added to prevent the removal of Mitre scale from the proper position.

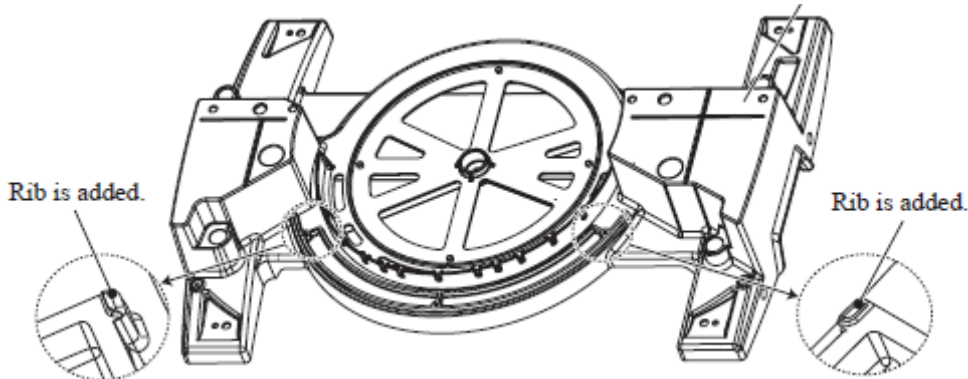

Note in assembly: Fasten Tapping screws while holding the edge of Mitre scale plate to the ribs as follows.

